

Helix

Spiral mixer

MADE IN ITALY

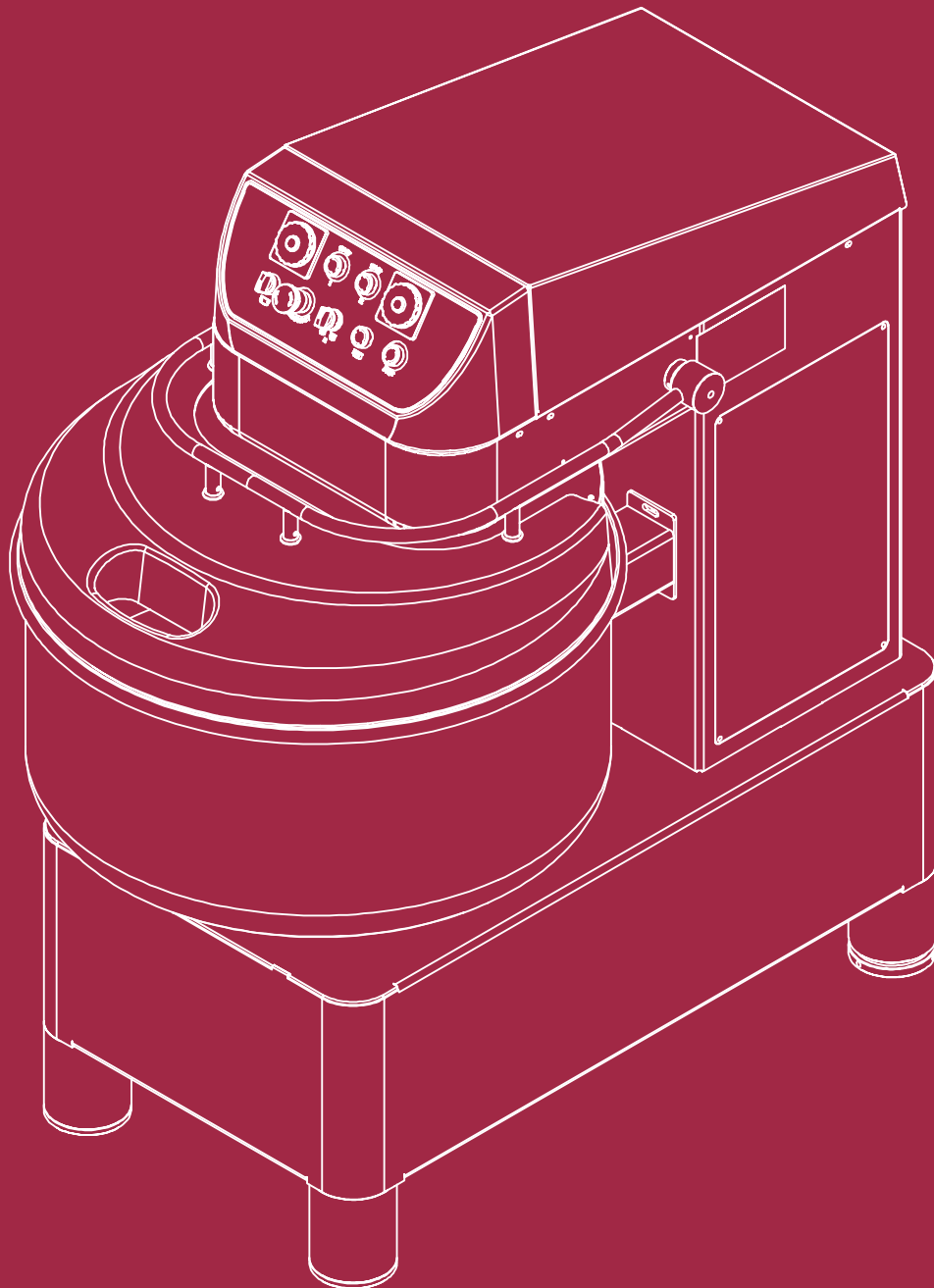

**Tekno
Stamap**

www.teknostamap.com

Technology boosting creativity

Helix

Intro

p.2

With fixed bowl

p.3

Helix

Spiral mixer

UNIVERSAL AND STRONG

Tekno Stamap spiral mixers are the newcomers to the already vast range of kneading and mixing machines. They are the answer to the need of the commercial network which, trusting a well-known and reliable brand, strongly wanted the birth of this new product.

The mechanics of the Helix mixers from the smallest of 45 kg to the largest of 200 kg are characterized by large bearings mounted on removable supports, heat treated steel shafts, anti-corrosion cast iron transmission pulleys and high quality transmission belts. The universality of the Helix lies in the ability to mix all types of dough, from those with less hydration to extreme ones, with very high hydration. In compliance with European regulations,

the machines are supplied with closed PETG protection, equipped with gas springs to facilitate controlled lifting and closing.

The food contact areas (MOCA), including screws, lids and supports, are entirely in stainless steel, thus ensuring hygiene and ease of cleaning. The painting of the structure is food grade, extremely robust and resistant to accidental scratches. For more than 10 years Tekno Stamap has been developing internal carpentry to meet the needs of a market that is increasingly attentive to the strength of the structures (sheet thickness, robotic welding and finishes that make our structures easy to clean).

A peculiarity of the Helix mixers is given by the stainless steel feet which, even if painted, maintain their characteristic of being anticorrosive.

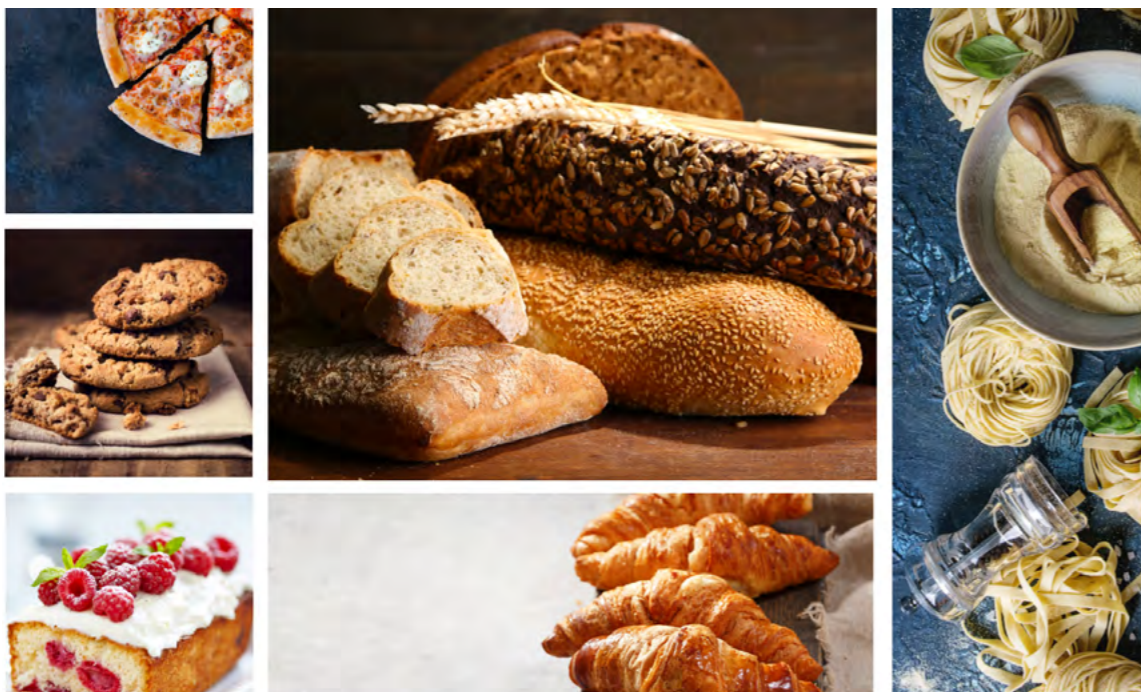

Ideal for bakeries, pizzerias, fresh pasta workshops, pastry shops, restaurants.

Fixed Bowl Helix from 45 to 200

Thermoformed front head cover

Rear cover in painted steel

Bowl protection in transparent PETG
* available in rods for non-CE markets.

Bowl, spiral and contrast column in stainless steel

Bowl reflection rollers

Painted steel structure raised from the ground (3 fixed feet and one adjustable)



CONTROL PANEL



2 SPEEDS WITH TIMER

Use in the manual version involves setting the working time with automatic passage from first to second speed; it includes the bowl rotation impulse button to facilitate the extraction of the dough, the bowl motion inversion selector, the 3 position selector for bowl motion (slow, neutral / crazy, fast).



2-SPEED DIGITAL CONTROL PANEL (ID)

It allows use in manual, semi-automatic and automatic versions. In semi-automatic operation it is possible to acquire the necessary times of dough processing. In automatic operation it is possible to memorize up to 20 work programs and recall them if necessary while maintaining the personalization of each individual phase. The digital version uses a sophisticated light diagnostics system which allows the user/ technician to identify any operating anomalies.

Optional: Dough temperature probe

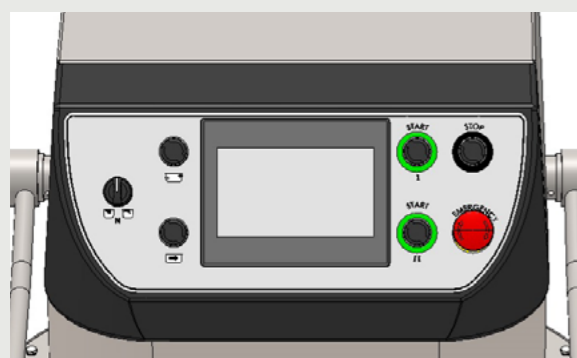

PROGRAMMABLE 2 SPEED TOUCH SCREEN (TS)

Multifunction programmable touch screen panel. This human machine interface has always been part of the Tekno Stamap philosophy; it is already used in various types of machines such as automatic sheeters, planetary mixers, make up lines, croissant machines and allows you to shorten the distance between Tekno Stamap and the user of the machine. The panel has memorized 16 languages to facilitate the understanding of the commands. It allows use in manual, semi-automatic and automatic versions. In automatic operation it is possible to memorize up to 30 work programs, including operations such as: delayed start, pauses for leavening in the bowl or adding ingredients, resumption of the program at any speed and with any preset time. Programs can be named and recalled if necessary.

Optional:

- Dough temperature detection probe
- Water dosing system by means of liter-counter
- Possibility of remote connection (4.0) to update software, check the operating status of the machine and identify any anomalies, acquire and duplicate programs on other machines in series, check work cycles, production and usage time.

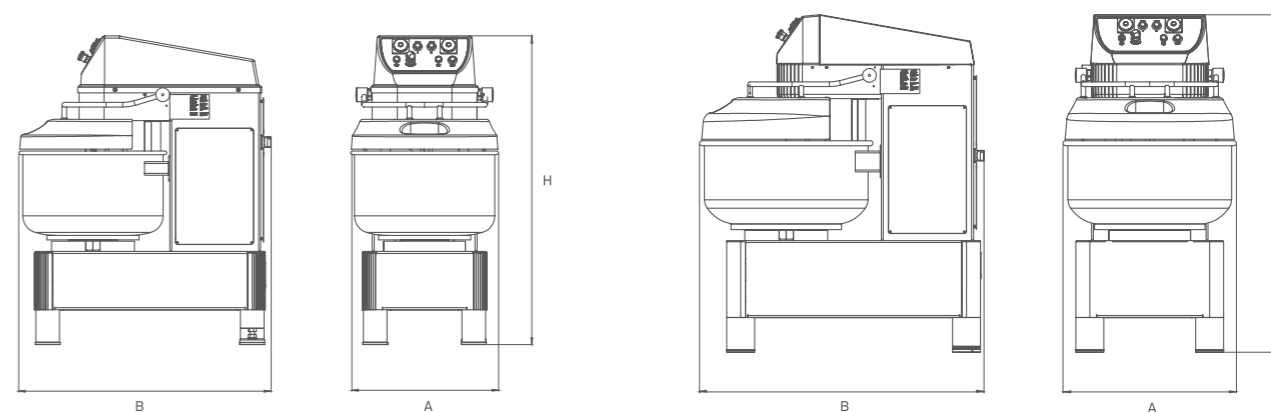

Technical data

Helix	U.M.	Helix 45	Helix 60	Helix 80	Helix 100	Helix 130	Helix 160	Helix 200
Machine dimensions (A x B x H)	mm.	637 x 1085 x 1325	745 x 1225 x 1450	842 x 1355 x 1450	952 x 1490 x 1530			
Packaging dimensions	mm.	750 x 1180 x 1610	865 x 1340 x 1670	965 x 1471 x 1670	1072 x 1605 x 1740			
Bowl dimensions (Ø x H)	mm.	600 x 300	600 x 360	700 x 360	700 x 410	800 x 415	900 x 420	900 x 450
Dough capacity	Kg.	45	60	80	100	130	160	200
Nominal volume of the bowl	L	80	95	120	145	200	250	270
Nominal electrical power 1st speed	kW	2		2,7	3,6		6,6	
Nominal electrical power 2nd speed	kW	3,4		5,1	5,8		10	
Power supply voltages	V	230-400						
Frequency	Hz.	50/60						
Electrical phases		3P + neutro + terra						
Net weight of the machine	Kg.	372	375	530	540	630	730	740
Net weight of the machine + packaging	Kg.	457	460	600	610	700	800	810
Spiral revolutions 1st / 2nd speed (50 Hz.)	RPM	101 / 203		94/189	94/189		89/178	
1st / 2nd speed bowl revolutions (50 Hz.)	RPM	11		9	10		9/18	

Optional:

- 2-speed bowl motor (standard for 160 and 200)
- Structure in stainless steel
- Dough temperature probe (only with ID or TS panel)
- Internal bowl lighting lights
- Arrangement for flour filler neck
- Water dosing system by means of liter-counter (only with TS panel)
- HP version available with spiral motor with "increased" power and lower stress spiral motor drive transmission

Tekno Stamap

Via Tretti Marotti, 8
36040 Grisignano di Zocco
Vicenza _ Italy

T. +39 0444 - 414 735
F. +39 0444 414 719

www.teknostamap.com
info@teknostamap.com